



by Gardner Denver

CAPTURE[®] PUMP MODELS CRR-1

for

Total Refrigerant Recovery and Recycling Systems

Contents: Installation
 Operation
 Maintenance
 Parts List
 Accessories
 Warranty



WARNING

Do not operate CAPTURE pump model numbers CRR-1A, -1B at discharge pressures above 30 PSIG.

Section 1: INSTALLATION

1.1 Introduction

This manual has been compiled not only for the care and maintenance of the CAPTURE™ pump now in your possession, but as a helpful reference guide for many problems which are usually associated with CAPTURE pumps. Take time to read these instructions carefully and preserve this manual for future reference, we think it will be useful to you.

1.2 Unpacking

Carefully remove the CAPTURE pump from the shipping case and unfasten and remove the wooden skid. Preserve all paper work and inspection tags for future reference. If damage has occurred from shipment a claim must be filed with the carrier immediately; preserve the shipping container for inspection by the carrier. If you are required to communicate with your CFC Recovery System Supplier or with Welch Vacuum Technology, Inc. be sure to include your order numbers for quick identification. Do not return the pump to the factory without first calling for a Return Goods Number (RGA) number.

1.3 CAPTURE Pump Mounting

1.3a Mounted CAPTURE Pumps

All CAPTURE pumps should be mounted in a horizontal plane.

1.3b Unmounted Pumps

If you have purchased an unmounted CAPTURE pump, refer to drive requirements table in this manual for information concerning the motor, motor pulley and belt necessary to drive your model CAPTURE pump at the recommend speed.

1.4 Pump Location

The Recovery and/or Recycling System containing the CAPTURE pump should be located preferably in a clean and well ventilated area.

1.5 Discharge Provisions

The discharge connection on CRR-1 is 1 inch female NPT. An oil separator needs to be attached to the discharge of the CAPTURE pump. The oil return on the oil separator must be connected to the flare fitting located near the suction port.

CAPTURE pumps should not be run at discharge pressures above 30 PSIG when using a 1HP motor with CRR-1.



WARNING

The recovery and/or recycling system containing a CAPTURE pump must employ some type of safety device to prevent the CAPTURE pump from running higher than 30 PSIG.

All models of CAPTURE pumps have pump shells rated at 100PSIG. Do NOT allow pumps to pressurize above 100 PSIG.

1.6 Electrical Power

1.6a Power Source Review

Review the power source and the motor rating to be sure they agree in voltage, phase and frequency. On three-phase applications the direction of rotation of the motor must be considered. Make a momentary check of rotation at the time of power installation and wiring. Momentary backward rotation of the pump is not harmful. Check the dimensional diagrams in this manual for proper direction of rotation for both CAPTURE pumps.

1.6b Overload Protection

Motor thermal overload protection is made available by the motor manufacturer as an aid to minimizing motor failure. Overload protection is a standard feature on all single-phase 60 Hz motors. Single-phase motors have automatic overload protection.

Welch strongly suggests that you familiarize yourself with the protection supplied with your motor so that you may react accordingly in the event of an emergency. Automatic reset protection is designed to reset itself after a predetermined cooking period. If the fault is corrected. The motor data plate will indicate the presence of thermal protection.

1.7 Suction Port Connections

1.7a Choice of Connections

The choice of piping and valves can have a very marked effect on the pumping speed. Long, small diameter piping or valves connecting the chiller will reduce the CAPTURE pumps rated pumping speed. Lower pumping speeds will increase the time needed to recover the refrigerant vapor to 29 inHg.

Welch strongly recommends that the recovery and/or recycling system should have as few valves as possible between the suction port and the chiller. The valves employed must fully open and be sized for the thread used on the suction port.

It has been show that the conductance of a tube is proportional to the cube of its diameter and inversely proportional to its length. Therefore it is imperative that the connecting lines be as large in diameter and as short in length as practical. For best results the diameter of the connecting tube should be at least as large as the diameter of the suction port. To avoid a large reduction in pumping speed at the chiller, the tubing connecting the chiller to the recovery and/or recycling system be as large in diameter and short as possible.

1.7b Metal Joints

When metal piping or tubing is used, it is preferable to solder or braze all the connections. Where threaded joints must be used, coat the threads with PTFE thread sealant and screw together tightly. Flanged connections with elastomer gaskets make excellent demountable joints.

1.8 Vacuum and Pressure Gauges

Two dual vacuum and pressure dial gauge marked off in inches of Hg (or Torr) and PSIG (or Pascal) should be located both on the discharge and suction ports. The gauges can act to visually warn an operator if excessive pressure build-up is occurring and how good a vacuum the chiller is under.

An automatic high pressure limit switch is still required even when two dual vacuum and pressure dial gauges are used.

1.9 Type of Lubricant

All CAPTURE pumps are tested with DUOSEAL® brand oil and shipped with a full charge to prevent unnecessary contamination. The oil acts both as a lubricant and the vacuum seal between the rotating components. An additional supply of oil is furnished with each pump with instructions to drain and discard the oil contaminated in the pump and replace with the fresh oil. DUOSEAL® oil has been especially prepared and is ideally suited for use in CAPTURE pumps because of its desirable viscosity, low vapor pressure and chemical stability. The vacuum guarantee on all CAPTURE pumps applies only when DUOSEAL oil is used.

Section 2: OPERATION

2.1 Starting Procedures

2.1a Starting a CAPTURE Pump

Before installing the CAPTURE pump in a recovery and/or recycling system it is well to familiarize yourself with the function and action of the pump which you have now acquired. Remove the suction and discharge port plugs and temporarily provide a stopper for the suction. The suction port is marked IN. The discharge port is marked OUT. Review the power requirements as described in Paragraph 1.6.

2.1b Cleanliness

Take every precaution to prevent foreign particles from entering the pump. A fine mesh screen is provided for this purpose in the intake passage of all CAPTURE pumps.

2.1c Oil level Determination

The amount of oil suitable for efficient and satisfactory performance should be determined after the pump has reached its operating temperature. Initially, however, the pump should be filled with fresh oil while the pump is idle. Fill the pump through the oil fill port. Correct oil fill is approximately 3/4 full when looking at oil sight glass. Maintain oil between Min-Max lines as indicated by sight glass marking. If after a short period of operation the level should fall, it is likely the result of oil entering some of the interior pockets of the pump. If the oil level rises, this signifies oil had drained into the pump cavity while pump was idle. Shut off pump, then drain oil down to proper level.

If a gurgling sound occurs, additional oil must be added. CAPTURE pumps will gurgle in varying degrees under four conditions of performance: (a.) when operating at high pressure as in the beginning cycles of evacuation of a chiller; (b.) when the oil level in the pump reservoir is lower than required; and (c.) when a large leak is present in the system. Awareness of the possibilities will save time in setting up a system.

CAUTION: Best performance of a CAPTURE pump is obtained after sufficient time has been allowed for the pump to come to operating temperature. If refrigerant vapor is pumped through the pump before the pump is warmed up, a large quantity of refrigerant will dissolve in the oil. The dissolved refrigerant will superheat and boil off violently as the pump approaches its operating temperature. Excessive oil loss will result. Intake valve should be open gradually to prevent sudden refrigerant rush to the pump.

2.2 Leak Detection

2.2a Large Leaks

The importance of eliminating all leaks in a recovery and recycling system is obvious when it is realized that a leak into the system, at atmospheric pressure, expands in volume by a factor of well over 1000. The CAPTURE pump must remove this added volume to maintain the desired vacuum. Fortunately a number of effective techniques for leak detection have been developed. Large leaks can be located by pressurizing the system and painting the suspected area with a thick soap solution. Escaping air will produce soap bubbles.

2.2b Small Leaks

Small leaks may be detected by spraying area with acetone or gases rich in hydrogen, and observing a sudden change in pressure on a thermocouple gauge. The difference in calibration of these gauges, for air and other gases, will produce a distinct change in the pressure reading. To use this method of detection, the system must be under vacuum and the gauge sensing tube must be located between the pump and the area to be probed. Use extreme caution, as these materials are highly flammable!

2.2c Fine Leaks

Locating very fine leaks requires a helium-sensitive, mass-spectrometer leak detector. This instrument will locate leaks which cannot be detected by any other method. Numerous fine leaks can have the total effect of a large leak.

2.3 Shutdown Procedures

2.3a CAPTURE Pump Shutdown

A few simple precautions are all that is necessary when a shutdown is in order. Turn off the power and open the recovery and/or recycling system to the atmosphere. Be sure the suction port and discharge port of the CAPTURE pump are brought up to atmospheric pressure at the same time. This step will prevent oil from being blown out of the CAPTURE pump.

If the pump is removed from the system, place over the suction and discharge ports a rubber stopper or suitable cover to protect the pump against and loose particles falling into the CAPTURE pump. If the pump has been contaminated in service and is going to be shelved for a prolonged period it is best to drain the oil and refill with a fresh charge.

Section 3: MAINTENANCE

3.1 Suction and Discharge Pressure Problems

3.1a Pressure Determinations

Leakage, oil contamination, V-belt and low oil level are four major causes of insufficient suction or discharge pressure. If the recovery and/or recycle system is free from leaks, and unwarranted suction problems still exist. The pump should be checked. A simple criterion for the condition of a CAPTURE pump is a determination of its ultimate pressure capability. This can be accomplished by attaching a dial vacuum gauge directly to the pump. Refer to Paragraph 1.8 for further suggestions. If the suction obtainable is very poor the pump may be badly contaminated, low on oil or malfunctioning. On the other hand, if the pressure is only slightly higher than the guaranteed ultimate pressure of the pump, an oil change may be all that is required.

If the recovery and/or recycle system is free from leaks and sufficient suction exists, but the discharge pressure is insufficient, there are several sources to the problem. A simple explanation is there is an insufficient flow or refrigerant vapor into the CAPTURE pump. Check to see that the tubing connecting the suction port to the chiller are not obstructed. A low oil level or v-belt slippage can cause the same symptoms. If there is a leak in the oil case of the CAPTURE pump, this can also cause insufficient discharge pressure. If none of these explanations fit the observations, the pump may be malfunctioning and should be sent back to a Welch repair facility.

3.1b Oil Contamination

The most common cause of a loss in efficiency in a CAPTURE pump is contamination of oil. It is caused by condensation of vapors and by foreign particles. The undesirable condensate emulsifies with the oil which is recirculated and subjected to re-evaporation during the normal cycle of pump activity thus reducing the ultimate vacuum attainable. Some foreign particles and vapors may form sludges with the oil, impair sealing and lubrication and cause eventual seizure. Periodic oil changes are necessary to maintain efficient operation of the system. The required frequency of changes will vary with the particular system. Experience with the process will help you determine the normal period of operation before an oil change is required.

3.2 Oil Changes and Oil Level

3.2a Draining the CAPTURE pump

An oil change is most easily accomplished with when the capture pump is warm and the oil is less viscous. Use a large container and open the drain valve. A thorough job may be accomplished by tipping the pump slightly if this is possible. The small residue remaining in the pump may be forced out by hand-rotating the pump pulley with the discharge port partially closed and the suction port open. Closing the discharge port completely under these conditions will create excessive pressure at the drain valve which may cause the oil being drained to splatter.

3.2b Flushing the CAPTURE Pump

After removing all the oil, close the drain and pour about four ounces of clean DUOSEAL® oil into the oil fill port (see exposed view drawing for your model CAPTURE PUMP). Open the discharge port and operate the pump for about a minute with the suction port alternately opened and closed to agitate and circulate the fresh oil. Again stop the pump, drain the flushing oil and force out the residue as before.

The amount of flushing oil and the number of flushes will be determined by the extent of contamination and the color of the oil. Under no circumstances should anything other than DUOSEAL oil be used for flushing a CAPTURE pump. The higher vapor pressures of other types of oil will cause difficulty later in the attainment of a vacuum.

3.2c Refilling the CAPTURE Pump

After you are satisfied that the pump has been thoroughly flushed, refill the pump by pouring new DUOSEAL oil into the discharge port. Fill to the recommended level and start the pump with the suction closed. A gurgling noise is characteristic when high pressure air is drawn through the pump. It should disappear quickly as the pressure within the pump is reduced. If gurgling continues, add sufficient additional oil through the oil fill port until gurgling ceases.

3.3 Shaft Seal Replacement

To replace the shaft seal of a pump, drain the oil and remove the pump pulley and key. Remove the screws securing the old seal and pry it loose with a screwdriver or similar wedge, being careful not to mar the surface of the pump body against which the seal fits. Discard the seal and its gasket. Inspect all surfaces and repair any damages with a fine abrasive stone. Wipe all sealing areas clean and place a film of DUOSEAL oil on both the shaft and the inside bore of the new shaft seal. Using a new gasket, carefully slide the new seal into position and center it on the shaft. It is not necessary to apply any sealant to the gasket. Tighten the mounting screws uniformly and refill the pump with DUOSEAL oil. Follow instructions included in repair kit.

3.4 Repairing Oil Leaks

3.4a Location, Cause and Effect

Oil leaks may develop wherever two mating faces are sealed with a gasket. Such seams may fail as the result of deterioration of the gasket material, loosening of the screws caused by temperature variations, or improper care as result of previous reassembly. Typical gasketed seams in a CAPTURE pump are located at the shaft seal and the mating faces of such mechanical surfaces as the suction chamber cover, the oil case, and the discharge chamber cover. The important of a gasketed seam is determined principally by its function. If it is a vacuum seal, the ultimate performance of the pump is dependent upon it. If it is an oil seal, the pump may be operated satisfactorily for some time without loss of function. Eventually, of course, a great loss of oil may cause harmful damage.

3.4b Repairing Technique

Thin composition gaskets are generally used for large irregularly shaped areas. A replacement joint of this type should be thoroughly cleaned of all previous gasket material and the mating surfaces cleaned of any nicks.

3.5 Repairing Vacuum Leaks

3.5a Surface Preparation

Good vacuum seals are an essential and important attribute of a CAPTURE pump. A good seal is dependent upon the quality of the mating surfaces as well as the sealant and its preparation. The mating faces should be carefully inspected for any projections or foreign particles which might interfere with proper mating. Slight projections such as nicks and burrs are most easily removed by rubbing with

a fine abrasive stone. The surface of the mating parts may be washed with a solvent or alcohol after which they must be thoroughly dried.

3.5b Temporary Repair

Temporary vacuum repairs are often made by covering the known leak with an industrial sealant such as PTFE thread sealant. Such a practice, however, is not recommended for seals of a permanent nature.

3.6 Drive Problems

If for any reason the pump will not operate, turn off the power and check the fuse and electrical connections. Then try the power to the motor only by removing the belt. If the motor operates properly try hand-rotating the pump in the proper direction with the pump suction port open. If both turn freely then replace the belt and check the belt tension. The tension should be sufficient to drive the pump without visible slippage. Any greater tension will cause noise and possible damage to the bearings of both the motor and pump. Make certain that both pulley grooves are clean and free from oil. The pulleys must be fastened securely on their respective shafts, and in parallel alignment.

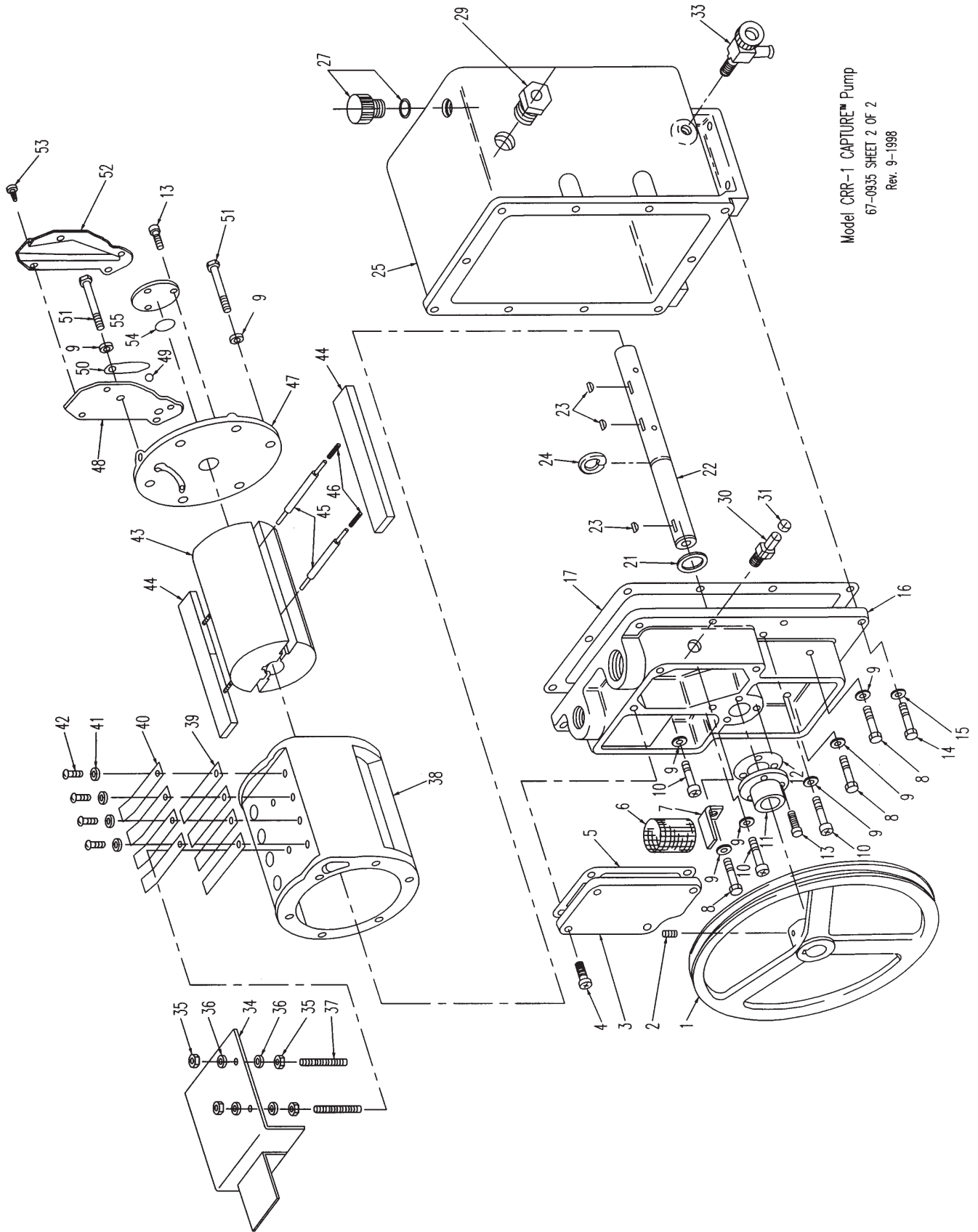

Model CRR-1 CAPTURE™ Pump
67-0935 SHEET 2 OF 2
Rev. 9-1998

PARTS LIST
MODEL CRR-1 CAPTURE™ PUMP

<u>ITEM</u>	<u>QTY</u>	<u>PART. NO.</u>	<u>DESCRIPTION</u>
1	1	41-2074	Pulley include Item 2
2	1	2-01-9306	Socket Head Set Screw 5/16-18x3/8
3	1	61-8671	Intake Cover Chamber
4	4	2-01-6112	Socket Head Screw 1/4-20x3/4
5	1	41-0234	Intake Cover Gasket
6	1	41-1692	Air Filter
7	1	41-0663	Air Filter Bracket
8	3	2-01-0316	Hex Head Screw 5/16-18x1
9	6	61-8456A	Washer, Copper 5/16
10	13	2-01-6316	Socket Head Screw 5/16-18x1
11	1	14010	Shaft Seal
12	1	41-0643	Seal Gasket
13	6	2-00-2706	Fil Head Screw 10-32x3/8
14	10	2-01-0114	Hex Head Screw 1/4-20x7/8
15	10	2-63-0356	Split Lock Washer 5/16
16	1	61-8416D	Large End Plate
17	1	41-0403	Oil Case Gasket
21	1	41-0508	Thrust Washer
22	1	41-1762	Shaft
23	3	41-0624	Woodruff Key
24	1	4-06-0754	Retaining Ring
25	1	61-8417D	Oil Case include Items 27, 29 & 33
27	1	41-3035	Oil Filler Plug
29	2	61-8482	Oil Sight
30	1	61-8481	Connector 1/4 NTP x 1/4 Flare
31	1	61-8423	Copper Seal Cap
33	1	726130	Drain Valve
34	1	61-8499B	Baffle Plate
35	4	2-31-0112	Hex Nut 1/4-20
36	4	2-61-3100	Steel Washer 1/4
37	2	2-01-8132	Set Screw 1/4-20x2
38	1	41-1760	Ring
39	4	41-1768	Lower Exhaust Valve
40	4	41-1779	Upper Exhaust Valve
41	4	2-61-0000	Steel Washer 3/16
42	4	2-01-5106	Round Head Screw 1/4-20x3/8
43	1	41-1761	Rotor
44	2	41-1684	Vane
45	2	41-1685	Vane Spring Holder
46	4	41-1304	Vane Spring
47	1	41-2045	Small End Plate
48	1	41-1005	Pressure Release Tube No.2
49	1	4-40-1200	Steel Ball 3/8
50	1	41-0992	Pressure Release Valve
51	6	2-01-0320	Hex Head Screw 5/16-18x1-1/4
52	1	41-0986	Pressure Release Tube No.1
53	3	62-0259	Self Tapping Screw #6x1/4
54	1	41-1766	Thrust Disk
55	1	41-0672	End Cap

67-0935 Sheet 1 of 2
Rev. 9-1998

CRR-1A and CRR-1B Dimensional Diagram

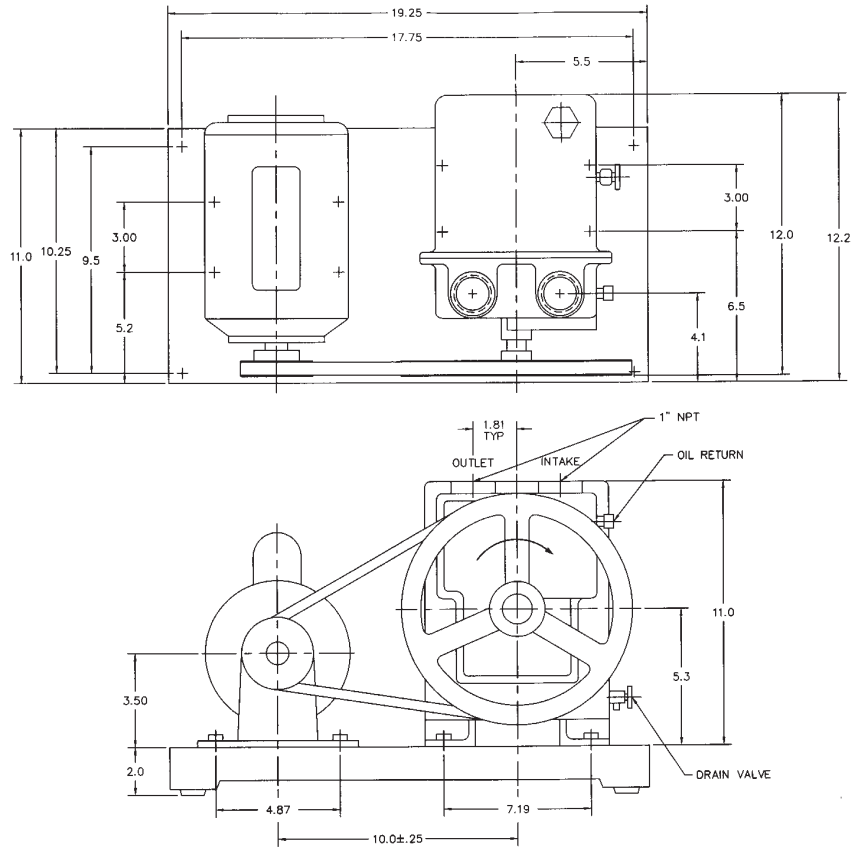

Capture Pump Accessories

<u>Welch Catalog Number</u>	<u>Description</u>
-----------------------------	--------------------

Oil Separation/Return Kit	
---------------------------	--

Pump Oil	
----------	--

1407K-11	1 Quart Oil for CAPTURE Pump
1407K-15	1 Gallon Oil for CAPTURE Pump
1407K-20	5 Gallon Container Oil for CAPTURE Pump
1407K-25	55 Gallon Drum, Oil for CAPTURE Pump

MODEL CRR-1 DRIVE REQUIREMENTS

Cat. No.	Belt No.	Motor Pulley No.	Motor No. HP	Volts	Hz	PH	RPM	Remarks
CPR-1A	1405A	41-0668	41-1940, 1 HP	115/230	60	1	1,725	Wired for 115V
CPR-1B	1405A	41-0667	61-8552, 1 HP	110/220	50	1	1,425	-

SPECIFICATIONS

CRR-1A,1B

Vapor Pumping Rate at atmospheric pressure, CFM		10.6
L/min		300
Ultimate Pressure, inch of Hg		29.9+
Torr		0.030
Pascal		4
Maximum Discharge Pressure, PSIG		30
Pascal		3.1 x 10 ⁵
Maximum Discharge Pressure, PSIG		30
Pascal		3.1 x 10 ⁵
Pressure Rating of Pump Shell, PSIG		100
Pascal		7.9 x 10 ⁵
Suction Connection 0 Female NPT, inch		1
Discharge Connection - Female NPT, inch		1
Oil Return Connection 45°Flare Fitting Size, inch		¼
Minimum Size of System Piping - NPT, inch		1
Oil Capacity (qts/1)		2.5/2.4
Pump RPM		525
Dimensions(in/cm)	Length	19.25/48.9
	Width	12.31/31.3
	Height	11.1/28.1

WARRANTY

This Welch product, sold by Welch-IImvac is warranted to be free from defects in material and workmanship. The liability of Welch-IImvac under this warranty is limited to servicing, adjusting, repairing or replacing any unit or component part which in the judgment of Welch-IImvac has not been misused, abused or altered in any way or damaged by ingestion of foreign material causing impaired performance or rendering it inoperative. Foreign materials includes solids, liquids, corrosive gases and recondensed water or solvent vapor. No other warranty: servicing, adjusting, repairing or replacing shall be at the discretion of Welch-IImvac. Vacuum pumps that have been operated within vacuum system, or other system, for any period, however short, will be repaired under this warranty rather than be replaced.

The warranty is effective for one year from the date of original purchase when:

1. The warranty card has been completed and returned.
2. The product is returned to the factory or other designated service centers, prepaid.
3. The product in our judgment is defective through no action or fault of the user.

If the product has become defective through misuse, abuse, alteration or ingestion of foreign material, repairs will be billed regardless of the age of the product. In this event, an estimate of the repair costs will be submitted and authorization of these charges will be required before the product is repaired and returned.

RETURN PROCESS

All returns (warranty or repairs) require a return authorization (RA). No return shipment can be accepted without an RA. To obtain an RA, please go to Welchvacuum.com - service & support.



WELCH by Gardner Denver
1601 Feehanville Drive, Ste 550
Mount Prospect, IL 60056
Phone: (847) 676-8800 (Technical Support)
Fax: (847) 677-8606
E-Mail: gdwelchvacuum@gardnerdenver.com
Web-Page: www.welchvacuum.com

OWNER'S MANUAL
For
CAPTURE® PUMPS
MODELS CRR-1
Part No. 67-0382A

CAPTURE, WELCH and DUOSEAL are registered trademarks of Gardner Denver, Inc.